



# Hi3536 H.265 CODEC Processor

## Key Specifications

### Processor Core

- ARM Cortex A17 quad-core@maximum 1.6 GHz
  - 32 KB L1 I-cache, 32 KB L1 D-cache
  - 1 MB L2 cache
  - Main control processor for running peripheral drivers and applications
- ARM Cortex A7 single-core@maximum 900 MHz
  - 32 KB L1 I-cache, 32 KB L1 D-cache
  - 128 KB L2 cache
  - Video-related module control

### Video Decoding Standards

- H.265 Main Profile L5.1
- H.264 Baseline/Main/High profile L5.0
- MPEG4 SP L0-3/ASP L0-5
- MJPEG/JPEG baseline

### Video Encoding Standards

- H.264 Baseline/Main/High profile L5.1
- MJPEG/JPEG baseline

### Video Encoding/Decoding

- H.265/H.264&JPEG encoding and decoding of multiple streams:
  - 4-channel 4K x 2K (3840 x 2160)@30 fps H.265/H.264 decoding+2x1080p@30 fps H.264 encoding+4-channel 4K x 2K@2 fps JPEG encoding
  - 16x1080p@30 fps H.265/H.264 decoding+2x1080p@30 fps H.264 encoding+16x1080p@2 fps JPEG encoding
  - 9x1080p@30 fps H.265/H.264 decoding+4K x 2K@30 fps H.264 encoding+9x1080p@2 fps JPEG encoding
  - 32x720p@30 fps H.265/H.264 decoding+4x720p@30 fps H.264 encoding+32x720p@2 fps JPEG encoding
  - 64xD1@30 fps H.265/H.264 decoding+8xD1@30 fps H.264 encoding+64xD1@2 fps JPEG encoding
  - 9x720p@30 fps JPEG decoding
- CBR or VBR, ranging from 16 kbit/s to 40 Mbit/s
- Encoding frame rate ranging from 1 fps to 60 fps
- ROI encoding
- Color-to-gray encoding

### GPU

- Integrated Mali-T720 GPU
- OpenGL ES3.1/2.0/1.1
- OpenCL 1.2/1.1/1.0
- Up to 63 MTris/s triangle filling rate
- Double-precision FP64 and anti-aliasing

### Intelligent Video Analysis

- Integrated IVE 2.0, supporting various intelligent analysis applications:
  - Motion detection
  - Video diagnosis
  - Perimeter protection
  - Face detection

### Video and Graphic Processing

- 3D denoising, deinterlacing, edge smoothing, dynamic contrast enhancement and sharpening
- Anti-flicker for output videos and graphics
- 1/8x to 16x video scaling
- 1/2x to 2x graphic scaling
- Four cover regions
- OSD overlaying of eight regions

### Video Interfaces

- VI interfaces
  - One BT.1120 HD input port
  - One video input channel for dual-chip cascading
  - SDR and DDR modes
  - Maximum input of 1080p@60 fps in SDR mode
  - Maximum input of 3840 x 2160@30 fps in DDR mode
- VO interfaces
  - One HDMI 2.0 ultra-HD output interface, support output up to 3840 x 2160@60 fps
  - One VGA HD output interface, support output up to 2560 x 1600@60 fps
  - One BT.1120 HD output port, supporting the maximum output of 1080p@60 fps in SDR mode or 3840 x 2160@30 fps in DDR mode
  - Two independent HD output channels (DHD0 and DHD1), output from any HD interface (HDMI, VGA, and BT.1120)
  - 64-picture output for DHD0, maximum 3840 x 2160@60 fps output
  - 32-picture output for DHD1, maximum 1080p@60 fps output
  - One CVBS SD output interface
  - Three full-screen GUI graphics layers in RGB1555 or RGB8888 format, used by two HD channels and one SD channel
  - Two hardware cursor layers in RGB1555, RGB4444 or RGB8888 format, with the maximum resolution of 256 x 256

### Audio Interfaces

- One integrated audio CODEC
- Three unidirectional I<sup>2</sup>S/PCM interfaces
  - One input, supporting 16 multiplexed inputs
  - Two outputs
- 16-bit audio input and output

### Ethernet Ports

- Two gigabit Ethernet ports
  - RGMII, RMII, and MII modes
  - 10/100 Mbit/s full-duplex or half-duplex
  - 1000 Mbit/s full-duplex
  - TOE for reducing the CPU usage

### Security Engine

- AES, DES, 3DES algorithms



# Hi3536 H.265 CODEC Processor

- SHA abstract algorithm

## RAID Acceleration Engine

- XOR acceleration
- Up to nine data sources for XOR
- DMA, up to 16 MB data block
- Memory initialization (configurable initial value)
- Descriptor linked list

## Peripheral Interfaces

- Two SATA 3.0 interfaces
  - PM
  - eSATA
- One PCIe 2.0/SATA 3.0 interfaces
  - Two PCIe interfaces, one PCIe interface+one SATA interface, or two SATA interfaces
  - RC and EP supported as the PCIe 2.0 interface
  - eSATA supported as the SATA 3.0 interface
- Two USB 2.0 host ports, supporting hub
- One USB 3.0 host port, supporting hub
- Two SDIO interfaces
  - SD 2.0, SDIO 2.0, MMC 4.4.1, and SDXC (only 3.3 V mode) cards supported for SDIO0 and SDIO1
  - Only eMMC 4.5 card supported for SDIO1
  - Multiplexing between SDIO0 and BT.1120 output pins
  - Multiplexing between SDIO1 and NAND flash interface pins
- Four UART interfaces, two of which supporting four wires
- One IR interface
- One I<sup>2</sup>C interface
- Multiple GPIO interfaces
- One low-speed ADC interface

## Memory Interfaces

- Two 32-bit DDR3/4 SDRAM interfaces
  - Maximum frequency of 933 MHz (1.866 Gbit/s)
  - Dual channels
  - ODT
  - Maximum capacity of 3 GB
- SPI NOR/NAND flash interface
  - 1-/2-/4-bit SPI NOR/NAND flash
  - Two CSs
  - Maximum 32 MB for each CS (for only the NOR flash)

- Maximum 8 GB for each CS (for only the NAND flash)
- 2 KB/4 KB page size (for only the NAND flash)
- 8-/24-bit ECC (for only the NAND flash)

- NAND flash interface
  - 8-bit NAND flash
  - Two CSs
  - SLC or MLC
  - 4-/24-/40-/64-bit ECC
- Embedded 64 KB BOOTROM and 88 KB SRAM

## RTC with an Independent Power Supply

- Independent battery for supplying power to the RTC

## Boot Modes

- Booting from the BOOTROM
- Booting from the SPI NOR flash
- Booting from the SPI NAND flash
- Booting from the NAND flash
- Booting from the eMMC
- Booting from the DDR (initialized over PCIe)

## SDK

- Linux 3.10-based SDK
- Audio encoding and decoding libraries complying with various protocols
- High-performance H.265/H.264 PC decoding library

## Physical Specifications

- Power consumption
  - Typical power consumption of 4.3 W
  - Multi-level power-saving control
- Operating voltages
  - 0.9 V core voltage
  - 1.0 V CPU voltage (or decreased to 0.9 V)
  - 3.3 V I/O voltage
  - 1.5/1.2 V DDR3/4 SDRAM interface voltage
- Package
  - RoHS, EDHS-PBGA
  - Ball pitch of 0.8 mm (0.02 in.)
  - Body size of 27 mm x 27 mm (1.06 in. x 1.06 in.)
- Operating temperature ranging from 0°C (32°F) to 70°C (158°F)

# Hi3536 H.265 CODEC Processor

## Functional Block Diagram

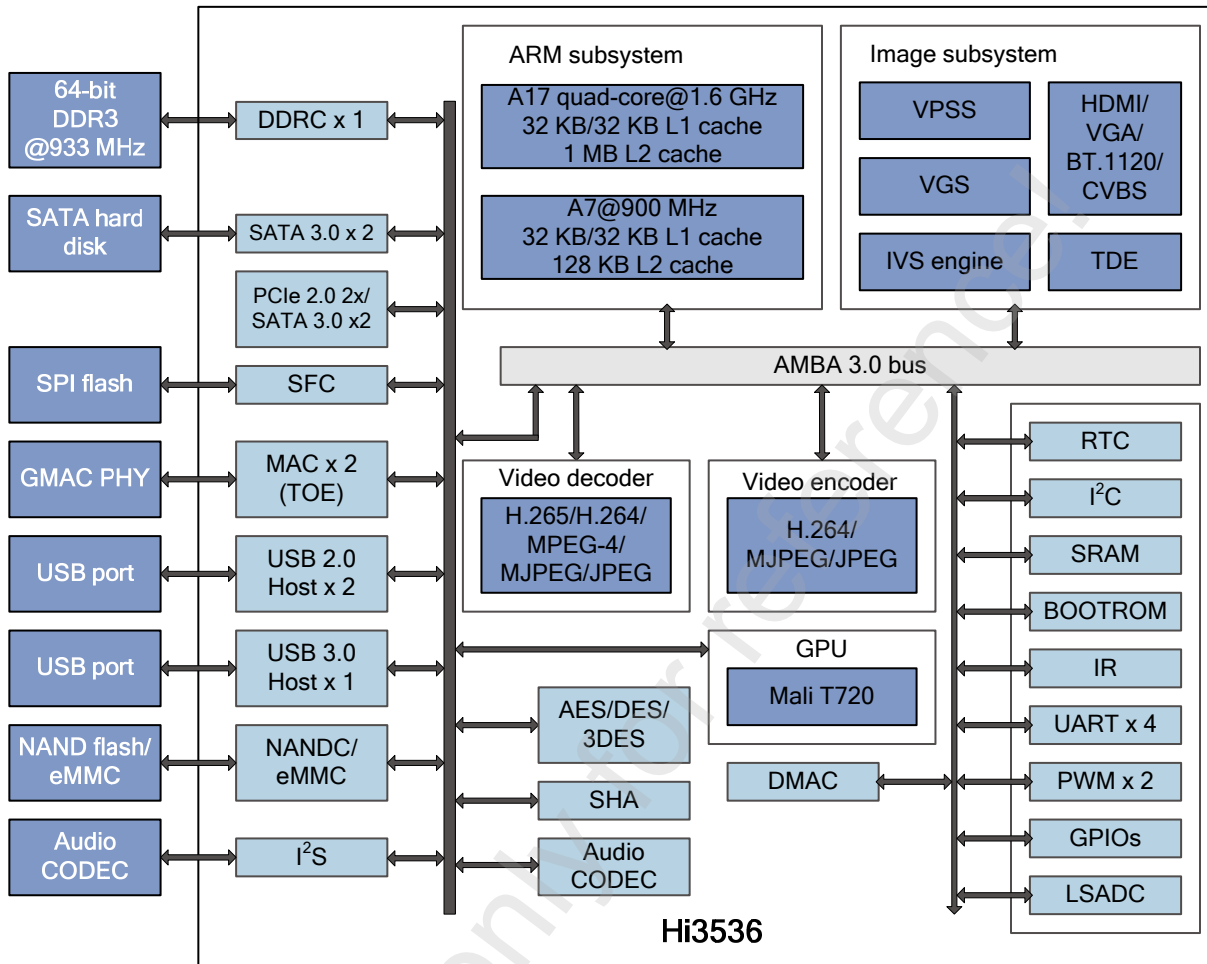

The Hi3536 is a professional high-end SoC targeted for the multi-channel HD or D1 NVR. The Hi3536 provides a high-performance A17 processor, a video decoding engine (a maximum of 16x1080p decoding complying with various protocols), a high-performance video/graphics processing engine (various complicated graphics processing algorithms), and dual-channel HD outputs. These features enable the Hi3536 to provide high-quality images. In addition, the Hi3536 integrates various peripheral interfaces to meet differentiated customer requirements for functionality, features, and image quality, while reducing the eBOM cost.

## NVRs (Each with a Hi3536)

### 16x1080p NVR

- 32x1080p@10 Mbit/s streams
- 16x1080p real-time decoding (16-channel polling previewing)
- 2x1080p real-time encoding
- 1080p@32 fps JPEG snapshot
- HDMI 4K x 2K@30 fps 16-picture ultra-HD output

### 32x720p NVR

- 64x720p@5 Mbit/s streams
- 32x720p real-time decoding (32-channel polling previewing)
- 4x720p real-time encoding



# Hi3536 H.265 CODEC Processor

- 720p@64 fps JPEG snapshot
- HDMI+VGA 1080p@60 fps HD dual 16-picture output

## 64xD1 NVR

- 128xD1@2.5 Mbit/s streams
- 64xD1 real-time decoding (64-channel real-time previewing)
- 8xD1 real-time encoding
- D1@128 fps JPEG snapshot
- HDMI 4K x 2K@30 fps 64-picture ultra-HD output

